

TS12

FEATURES

- Small-size, large capacity, excellent voltage holding.
- For all ratings, uniform 5 mm pitch of terminal spacing.
- Wider temperature range(-25~+70°C) than battery makes periodic change unnecessary.
- Ø13.5x7.5 size can encase up to 0.33F.
- Ideal for backing up of CMOS's, microcomputers, RAM's and the like used in VCR's, tuners, TV sets, telephone sets and other.



SPECIFICATIONS													
Operating temperature range (°C)	-25 to + 70												
Capacitance tolerance (%)	-20 to + 80												
Internal resistance at 1KHz	Standard Ratings, Miniaturized							High-Temperature -20 + 85°C, Coin Cell High Voltage					
	Capacitance (F)	0.047	0.1	0.22	0.33	0.47	1.0	0.047	0.1	0.22	0.47	0.68	1.0
	Internal resistance (Ω)	120	75	75	75	30	30	300	200	120	50	50	30
Stability at low & high temperature	Percentage of capacitance change	Within ±30% of the value at °C											
	Internal resistance	Less than five times of the value at 20 °C											
Endurance (70°C)	Test time	1000 hours											
	Percentage of capacitance change	Within ±30% of the initial measured value											
	Internal resistance	Within four times the initial specified value (Coin Cell High Voltage: Less than four times of the initial specified value)											
Shelf life (70°C)	Test time: 1000 hours : Same as endurance.												

Rated voltage (V)	Capacitance (F)	Standard Ratings	High-Temperature -20 + 85°C
		Ø D x L (mm)	Ø D x L (mm)
5.5	0.047	13.5 x 7.5	--
5.5	0.1	13.5 x 7.5	13.5 x 9.5
5.5	0.22	13.5 x 7.5	13.5 x 9.5
5.5	0.33	13.5 x 7.5	--
5.5	0.47	21.5 x 8	21.5 x 9.5
5.5	0.68	--	21.5 x 9.5
5.5	1.0	21.5 x 8	21.5 x 9.5

Coin Cell High Voltage

Rated voltage (V)	Capacitance (F)	Ø D x L (mm)
6.3	0.047	13.5 x 9.5
6.3	0.1	13.5 x 9.5
6.3	0.47	21.5 x 9.5
6.3	0.68	21.5 x 9.5
6.3	1.0	21.5 x 9.5

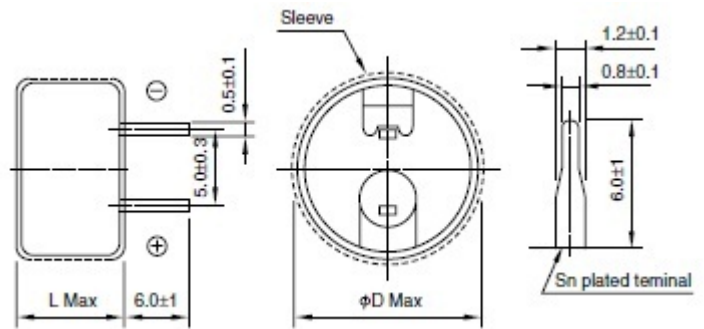

Miniaturized

Rated voltage (V)	Capacitance (F)	Ø D x L (mm)
5.5	0.047	11.5 x 13
		11.5 x 5
5.5	0.1	11.5 x 13
		11.5 x 5
5.5	0.22	11.5 x 13
		11.5 x 5
5.5	0.33	11.5 x 13
		11.5 x 5
5.5	1.0	19 x 20.5

Terminal shaped: V

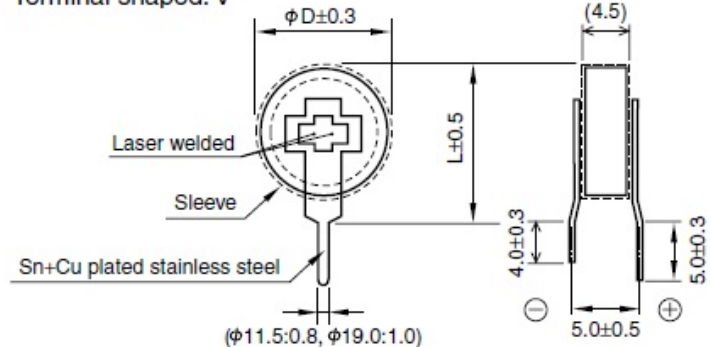

Terminal shaped: H

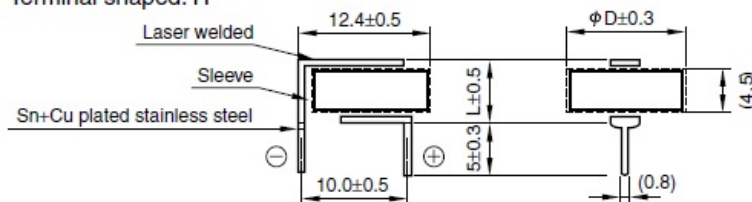

Note: Specification are subject to change without notice. For more detail and update, please visit our website.