

TS12-ML

FEATURES

- Low internal resistance
- Standard power type
- Pb-free and RoHS compliant



SPECIFICATIONS		
Series name	TS12-ML Series Low internal resistance Type	
Type name	TS12-ML 5R5	TS12-ML 7R5
Rated voltage V_R	5.5V	7.5V
Surge voltage	5.8V	7.9V
Capacity range	0.1F~5F	0.1F~3.3F
Operating temperature range	-40~ +70°C	
Product life	Normal temperature cycle life : 25°C, 1 million cycles between V_R and $1/2V_R$, Capacity attenuation $\leq 30\%$, ESR change ≤ 4 times.	
	High temperature endurance life : Maximum temperature retention V_R , 1000 hours. Capacity attenuation $\leq 30\%$, ESR change ≤ 4 times.	

DIMENSIONS (mm)

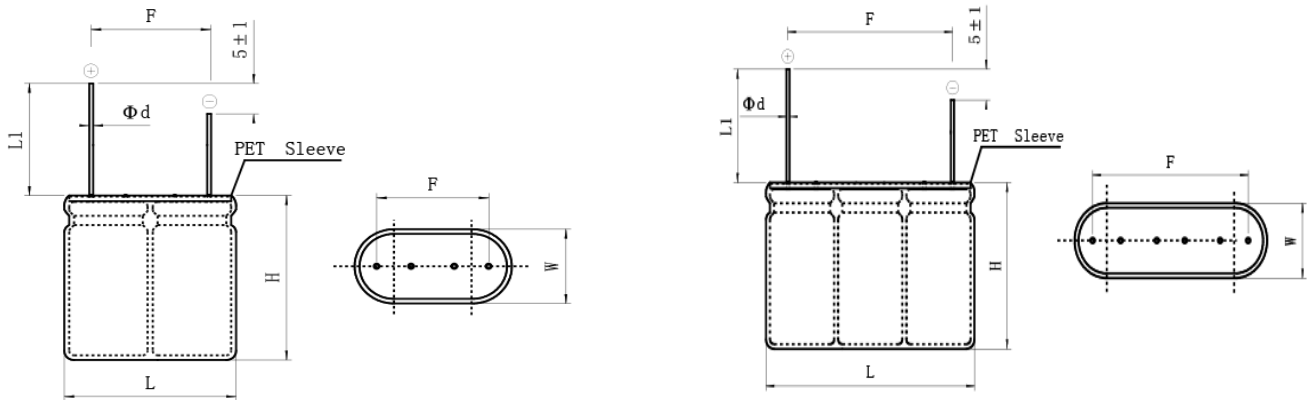

Note: Specification are subject to change without notice. For more detail and update, please visit our website.

TS12-ML

STANDARD RATINGS

Nominal Voltage (V)	Capacity (F)	ESR mΩ		Product size (mm)					
		DC	AC 1kHz	L+/-0.5	W+/-0.5	H+/-2	F+/-0.5	d+/-0.1	L1 min
5.5	0.1	1500	1000	11	6	13	7	0.5	26
5.5	0.1	1500	1000	13	7	14	9	0.5	26
5.5	0.22	1500	1000	13	7	14	9	0.5	26
5.5	0.33	1200	800	16.5	8.5	14	12	0.6	28
5.5	0.47	900	600	13	7	14	9	0.6	28
5.5	0.47	900	600	17	9	15	12	0.5	26
5.5	1	280	420	17	9	21	12	0.6	28
5.5	1	280	420	21	10	21	15	0.6	28
5.5	1.5	240	160	21	10	21	15	0.6 / 0.7	23
5.5	1.5	300	200	17	9	21	12	0.6 / 0.7	23
5.5	2	180	120	21	10	21	15	0.6 / 0.7	23
5.5	2	210	140	26	13	22	18	0.6 / 0.7	23
5.5	2.5	210	140	21	10	21	15	0.6 / 0.7	25
5.5	3	210	140	26	13	22	18	0.6 / 0.7	26
5.5	4	150	100	26	13	22	18	0.6 / 0.7	26
5.5	5	150	100	26	13	27	18	0.6 / 0.7	28
5.5	8	90	60	33	17	23	24	0.8	28
5.5	8	90	60	33	17	28	24	0.8	28
5.5	10	75	50	33	17	28	24	0.8	28
5.5	15	75	50	33	17	35	24	0.8	28
5.5	25	60	40	37	19	43	26	0.8	28
5.5	30	45	30	37	19	43	26	0.8	28
7.5	0.1	1800	1200	19.5	7	14	10	0.5	26
7.5	0.33	900	600	25	9	15	13.5	0.6	28
7.5	0.7	630	420	25	9	21	13.5	0.6	28
7.5	1	360	240	31	11	18	16	0.6	28
7.5	1	450	300	25	9	21	13.5	0.6	28
7.5	1.5	315	210	31	10	21	16	0.6	28
7.5	1.5	315	210	39	13	22	21	0.6	26
7.5	2	315	210	39	13	22	21	0.6	26
7.5	2.5	225	150	39	13	22	21	0.6	26
7.5	3.3	225	150	39	13	27	21	0.6	28
7.5	5	135	90	49	17	28	25.5	0.8	28